



ROEMHELD
HILMA ■ STARK

Contact:

Andreas Reich
Hilma-Roemheld GmbH
Head of QDC/QMC
Tel.: +49 2739 4037 162
Email: a.reich@hilma.de

F. Stephan Auch
auchkomm Unternehmenskommunikation
Tel.: +49 911 27 47 100
Email: fsa@auchkomm.de

Römheld GmbH
Friedrichshütte
Römheldstraße 1-5
35321 Laubach
Germany
Tel.: +49 (0) 6405 / 89-0
Fax: +49 (0) 6405 / 89-211
Email: info@roemheld.de
www.roemheld.com

DRAFT, Issue September 2, 2024

Press Release X/2024

- **ROEMHELD to premier latest innovations at the Fakuma trade fair: die changing console for loading injection moulding machines without a crane**
- **From the rack to the machine – set-up time optimizer to present integrated solutions for handling dies and moulds**

Laubach, September XX, 2024. ROEMHELD will premier at the Fakuma trade fair a flexible die changing console that can be used to load different injection moulding machines without a crane.

The set-up time optimizer will also present a wide range of components for complete solutions designed to handle moulds and dies along the entire process chain — from the rack to the machine.

ROEMHELD will be showcasing their new die changing console and product range for storing, transporting, changing and clamping at Fakuma from October 15 to 19, 2024, in Friedrichshafen, Germany, in Hall 1, Booth 1223.

New, flexible console for die and mould changing

ROEMHELD's new console simplifies die and mould changes on injection moulding machines. It is mechanically driven, movable and height-adjustable so that it can be used flexibly on different machines.

Roller feet help move the console to the desired machine and a lifting column raises the work surface to the correct height. There it is attached in place via a docking system and secured to prevent unwanted movement.

The mould can then be moved laterally from a transport cart onto the carrying console. To facilitate this, a circulating chain is attached and a crank handle permanently fixed to the console helps move the mould, first onto the work surface and from there, further into the system.

The new die changing console makes it easier to transport and change heavy loads between different storage and production sites. It is available in numerous variants and for all die dimensions



and weights. In addition to standardized consoles, ROEMHELD designs customized special versions for almost all requirements on request.

Everything from a single source

In addition to a comprehensive range of components for the storage, transport, changing and clamping of dies, ROEMHELD has now expanded its offering of integrated handling solutions. These range from storage systems and transport carts for loads between 500 kg and 40 tonnes to magnetic, hydraulic, electromechanical or purely mechanical clamping systems and comprehensive automation solutions.

About ROEMHELD:

Whether for aircraft, automobiles, machine tools, or cases for smartphones: ROEMHELD technologies and products have been used to manufacture numerous industrial commodities and goods for end users for more than 80 years.

Innovative and smart clamping technology solutions for workpieces, as well as for dies in forming technology and plastics processing, form the core of our steadily expanding portfolio. This is supplemented by components and systems for assembly and handling technology, drive technology and automation, and locking mechanisms for rotors on wind energy systems.

In addition to a constantly growing range of more than 25,000 catalogue items, ROEMHELD also specialises in developing and realising customised solutions and is internationally regarded as one of the market and quality leaders.

Innovation through tradition: ROEMHELD was established in 1707 with a foundry in Friedrichshütte, which still belongs to the ROEMHELD Group today and counts as one of Germany's oldest active industrial businesses.

The owner-managed group of companies employs approximately 530 workers at the three locations Laubach, Wilnsdorf and Rankweil/Austria and is represented in over 50 countries by service and sales organizations. With customers from the mechanical engineering sector and the automobile, aviation, and agricultural industries, ROEMHELD generates an annual turnover of more than 90 million euros.



Images:

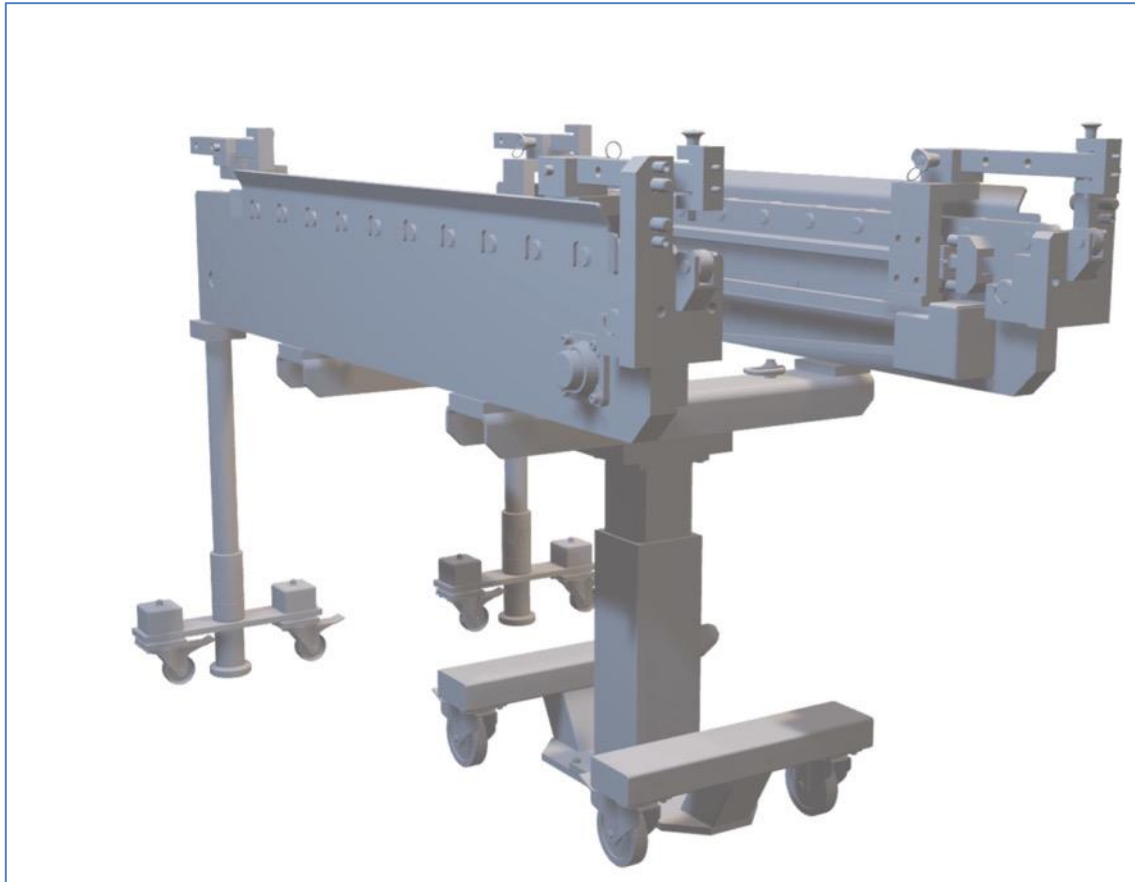

Image 1 (screenshot is placeholder, image in print resolution required):

ROEMHELD will premier at the Fakuma trade fair a die changing console that can be used to load injection moulding machines without a crane (Image: ROEMHELD).

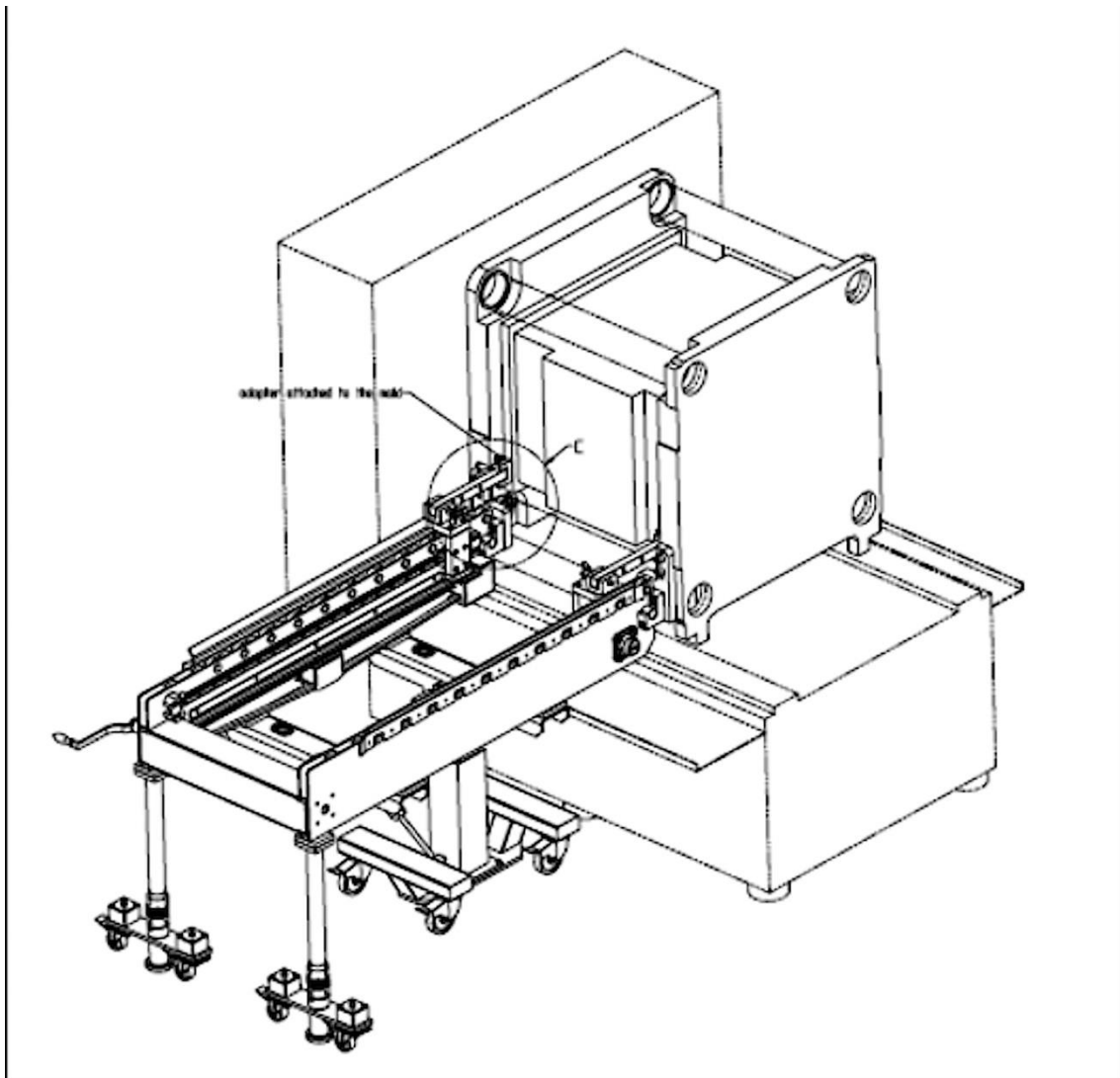

Image 2 (screenshot is placeholder, image without labelling in print resolution required):

The new console is mechanically driven, movable and height-adjustable so that it can be used flexibly on different machines and in different storage spaces (Image: ROEMHELD).



Image 3:

From the rack to the injection moulding machine and rubber press: ROEMHELD will present at the Fakuma trade fair its comprehensive portfolio of products for efficient handling of moulds and dies (Image: ROEMHELD).

You can download the press release as a Word document and the image material in print quality

<https://www.auchkomm.com/aktuellepresstexte>

Author's copy requested:

auchkomm Unternehmenskommunikation, F. Stephan Auch, Hochstraße 11, D-90429 Nuremberg,
fsa@auchkomm.de, www.auchkomm.de